



OWNER'S MANUAL

**!!PLEASE NOTE!!
THIS MANUAL MUST BE GIVEN
TO THE HOMEOWNER TO ENSURE
WARRANTY COVERAGE**

**American Swimming Pool System, LLC
927 Fern Street, Suite 1500, Altamonte Springs, FL 32701**

Toll Free: (866) 322-POOL (7665)

Tel: (407) 831-6154

Fax: (407) 831-1208

support@resiliencepool.com

www.resiliencepool.com

**Model: PSC-3
SCC-15/ SCC-25/ SCC-40**

November 2006

W E L C O M E

Congratulations on the purchase of your new Natural Chlorine Generator. Your purchase will minimize the efforts needed to maintain your pool and maximize your enjoyment for many years. Before installation or operation, please read these instructions carefully. This manual contains easy to follow step-by-step procedures to properly install and operate your system. A little time spent understanding your system and its parts will assure successful, trouble-free installation and usage. When working around your pool, please take care to avoid hazards such as electrical wires and chemicals. CAUTION! Safety comes first!

WARNING SAFETY FIRST

READ AND FOLLOW ALL INSTRUCTIONS

All electrical work must be performed by a licensed electrician and conform to all national, state, and local codes. Improper use or installation can badly harm the unit and its surroundings. When installing and using this electrical equipment, basic safety precautions should always be followed, including the following:

- DO NOT OPEN THE GENERATOR BOX – NOT A SERVICABLE UNIT
- Disconnect all AC power before installation.
- WARNING – To reduce the risk of injury, do not permit children to use this product.
- The Control Box must be mounted **vertically** on a flat surface, 2 pole circuit device must be used and a minimum of 5 ft (1.5m) horizontal distance (or more, if local codes require) from the pool/spa.
- In Canada and some other regions, local codes require the unit be connected only to a circuit that is protected by a ground-fault circuit-interrupter (GFCI). The installer should provide this GFCI requirement. The GFCI should be tested on a regular basis by pushing the test button. If the GFCI fails to operate correctly, there is ground current flowing indicating the possibility of an electric shock. Do not use this unit. Disconnect unit and have a qualified professional correct the problem before using.
- The power cable must be hardwired to the time clock so that the system cannot operate without the pump.
- A build-up of flammable fumes can result in a hazardous condition if the Cell is allowed to operate without flow. This machine must be operated only with an approved in-line flow sensor.
- The Flow Sensor must be installed between the last piece of apparatus and the Cell, upstream of the cell
- ALWAYS ADD ACID TO WATER, NEVER WATER TO ACID.
- SAVE THESE INSTRUCTIONS.

TABLE OF CONTENTS

WELCOME	
Safety First	2
INSTALLATION	
General.....	4
Cell	5
Flow Sensor.....	5
Control Box.....	6
Wiring	7
STARTUP	
Before Adding Salt.....	10
Adding Salt	11
How Much Salt to Add	11
OPERATION	
Background & Basic Operation.....	12
Controls	13
Maintenance / Cleaning	15
Understanding the Chemistry	17
Saturation Index.....	19
TROUBLESHOOTING	
Troubleshooting.....	20
WARRANTY	
Warranty & Registration.....	23

INSTALLATION INSTRUCTIONS

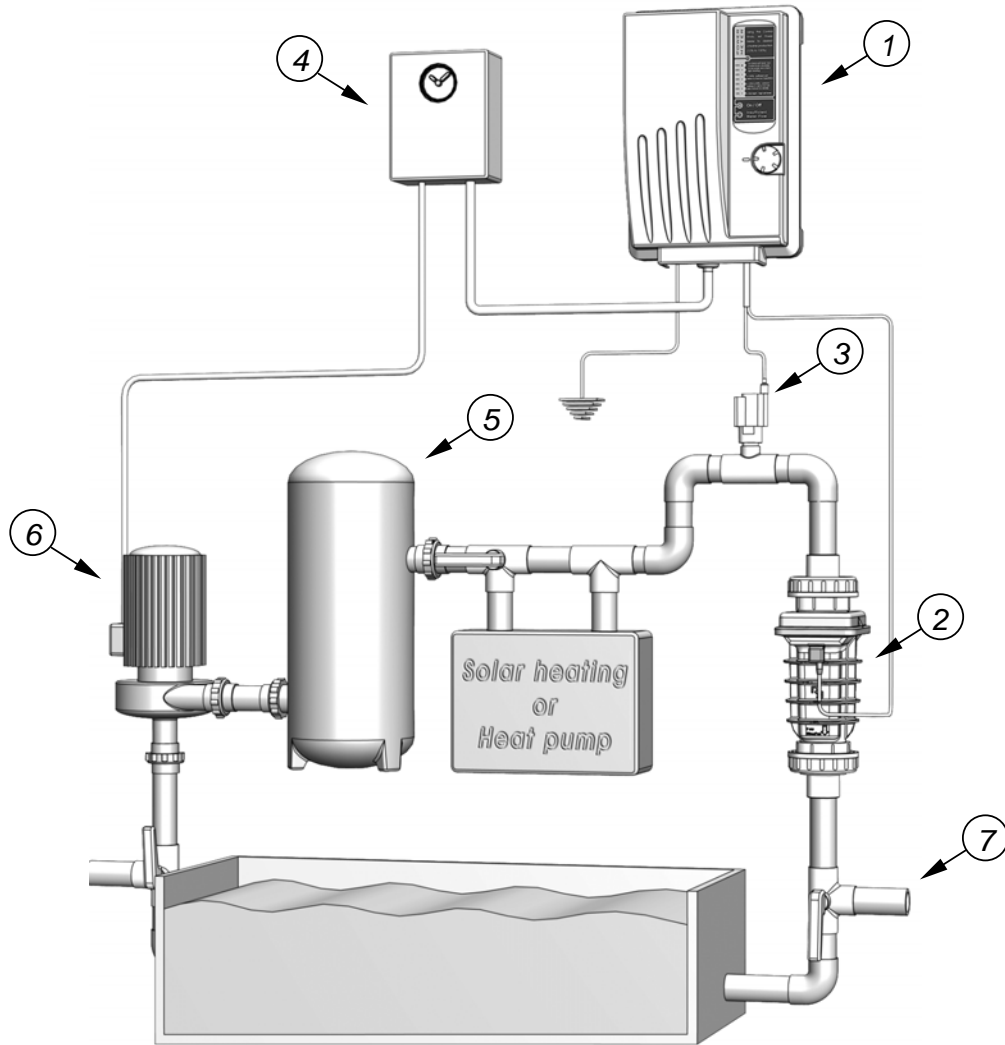

1. Control Box
2. Cell

5. Filter
6. Pump

→ **MODEL CONFIRMATION:** Confirm you have the correct model for your pool size by checking the model number on the Cell:

- SCC-15 < 15,000 gallons (60,000 liters)
- SCC-25 < 25,000 gallons (100,000 liters)
- SCC-40 < 40,000 gallons (150,000 liters)

3. Flow switch
4. Power / Timer

7. Spa line

The system comes in three sections, the Control Box, Cell and Flow Sensor. They are manufactured from the latest corrosion resistant materials to give you years of trouble free use, and installing them in the most sheltered position from sun and water will protect them from extreme weather conditions for years to come.

Safety Measures

1. Only operate the system with an approved flow sensor.
2. See safety measures and warnings on page 2 of this manual.

Additional Materials Required

- | | |
|---|--|
| 1. PVC solvent cement and priming fluid | 6. WD-40 |
| 2. Hacksaw or pipe cutters | 7. Silicone Sealant (NO NOT USE silicone glue or petroleum jelly). |
| 3. Screwdrivers | 8. Pipe adaptors (i.e. reducer couplings) if needed for systems with 1 ½ inch plumbing |
| 4. Drill | |
| 5. Teflon Tape (a.k.a. Plumber's Tape) | |

→ CONFIRM LAYOUT: Lay out equipment pieces to be sure there is enough pipe space between the last piece of apparatus and the tees in the return line to fit the Flow Sensor and the Cell. A Vertical installation may be used to save space (see diagrams above).

Install the Cell

1. The Cell and Flow Sensor must be installed downstream from the filter and heating devices but before any tees in the return line. The Cell may be installed horizontally or vertically so long as the Cell is pointed in the direction of flow and is installed immediately after the enclosed Flow Sensor (see diagram above).
2. Approximately 15 inches (~380 mm) of available pipe length will be needed for horizontal installations of the Flow Sensor and Cell. Vertical installations can be made to take less space.
3. On the pipe where the cell will be installed, mark two lines 11 3/4 inches (300mm) apart and cut out using hacksaw or pipe cutters.
4. Unscrew and remove the barrel unions (i.e. barrel nuts and slip connections) from either end of the Cell. Thread one of the barrel nuts over the pipe and glue its slip connection to the cut pipe.

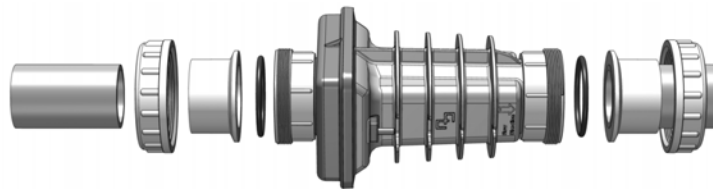

5. Hold up the Cell with the second union to gauge the proper distance before threading the second nut and gluing the second slip.
6. After the glue had sufficient drying time, place the Cell with the o-rings into the opening between the two ends of the pipe and tighten the unions making sure that the Cell is installed with the arrow pointing in the same direction as the flow (i.e. water should enter from the side with the blue cap).

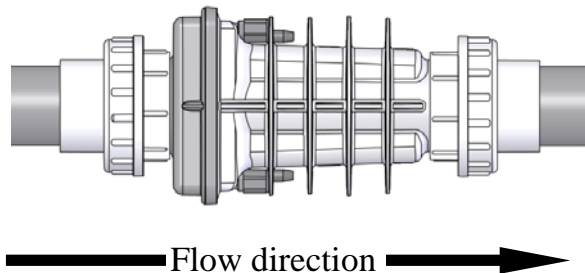

Install the Flow Sensor

1. Install the Flow Sensor between the last piece of apparatus and the Cell (if installed after the Cell, damage to the sensor may result). When possible, install on a horizontal pipe.
2. Mark two lines on the pipe 3 inches (~76 mm) apart and cut with a hacksaw or pipe cutters.
3. Clean and glue the "T" connector (included) to the pipe making sure that the threaded end with the sensor is on the topside of the pipe.
4. Be sure the arrow on the top of the Flow Sensor is pointing in the direction of flow, and that no glue touches the paddle inside the sensor as it may cause it to jam.

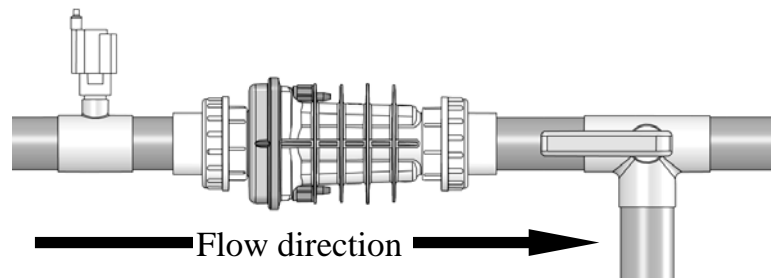

Mount the Control Box (PSC-2/PSC-3/PSC-4 Control Box works with SCC-15, SCC-25, SCC-40 Cells)

1. The Control Box must be mounted vertically on a flat surface and a minimum of 5 ft (1.5m) horizontal distance (or more, if local codes require) from the pool/spa.
2. Locate a position for your Control Box within 10 ft (3½ meters) of where the Cell will be installed and within 2 ft of the power supply to ensure enough wire is available.
3. Because the box acts as a heat sink dispersing heat from inside the box, do not block the four sides of the Control Box. **Do Not** mount the system inside a panel or tight enclosed area.

- | |
|--|
| <ol style="list-style-type: none"> 1. Flow sensor connectors 2. Cell connectors 3. Bonding 4. Power Cord |
|--|



4. Secure the hanging rack on the wall using the enclosed screws and anchors. 1/4" (8mm) drill bit should be used for the anchor holes.
5. Hang the Control Box on the mounted hanging rack.

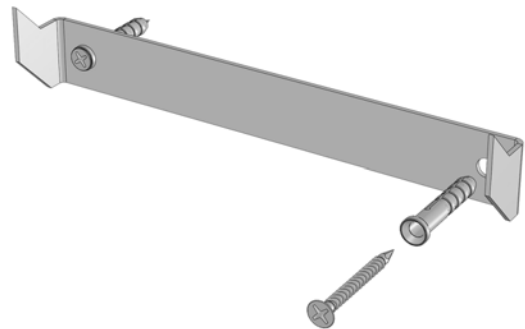
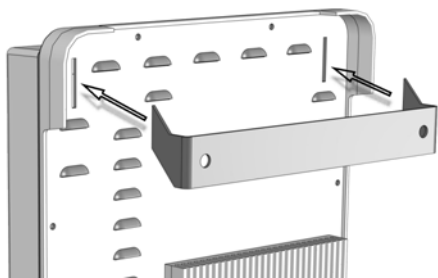

6. Hardwire the power cable to the time clock as indicated in the instructions below. *Check the label on the side of the Control Box for the proper voltage specification on your system (i.e. 120v or 240v).
7. Do not extend the cable leading to the cell. This decreases the system's efficiency and will void warranty coverage. Please contact the manufacturer for installations demanding a longer cell cable.

Wiring the Control Box to Standard Timer

→CAUTION: Check whether your chlorine generator operates on 120 volts or 240 volts (see label on the left side of the Control Box), and be sure to wire the system accordingly.

→CAUTION: It is critical to wire the chlorine generator in such a way that it can only operate when the pump is operating (i.e. load side). See instructions below for details.

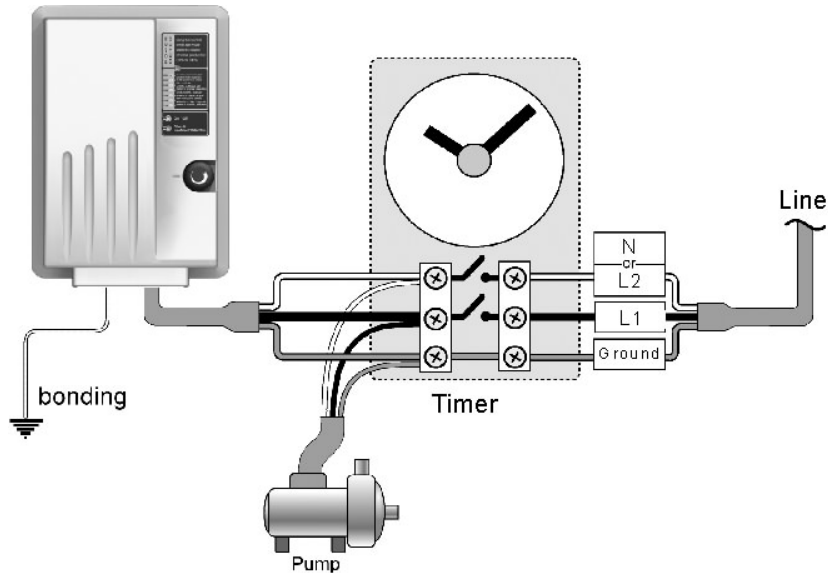

1. Attach the green ground wire to the grounding lug or bar.
2. Connect the black Load wire from the chlorine generator to Load 1 of the time clock.
3. If wiring a 240 Volt generator, connect the third wire to Load 2 of the time clock. If wiring a 120 Volt generator, connect the third wire to the Neutral lug or bar on the timer (see label on the left side of the Control Box to confirm voltage).
4. Bonding is recommended and may be required by local code. The bonding lug is found on the bottom of the Control Box.

Wiring the Control Box to Automated Systems

→CAUTION: Check whether your chlorine generator operates on 120 volts or 240 volts (see label on the left side of the Control Box), and be sure to wire the system accordingly.

→CAUTION: It is critical to wire the chlorine generator in such a way that it can only operate when the pump is operating (i.e. load side). See instructions below for details.

The Natural Chlorine Generator can operate with virtually any automated control system as an auxiliary.

1. Attach the green ground wire to the grounding lug or bar.
2. Connect jumper wires from the Load side of the Circulation Pump Relay to the Line side of an Auxiliary Relay as depicted in the relevant diagram below (based on the voltage used by the pump and the chlorine generator) and in accordance with instructions of the automatic controller manufacturer.
3. Connect the Natural Chlorine Generator to the Load 1 & 2 connectors of the Auxiliary Relay to control the generator's operation.
4. Bonding is recommended and may be required by local code. The bonding lug is found on the bottom of the Control Box.
5. Set the chlorine generator to 100% power, and program the Aux Relay to run the chlorine generator as needed. (e.g. 100%, 50%, 25% of the time the pump is running).

240Volt Circulation Pump With 240 Volt Chlorine Generator

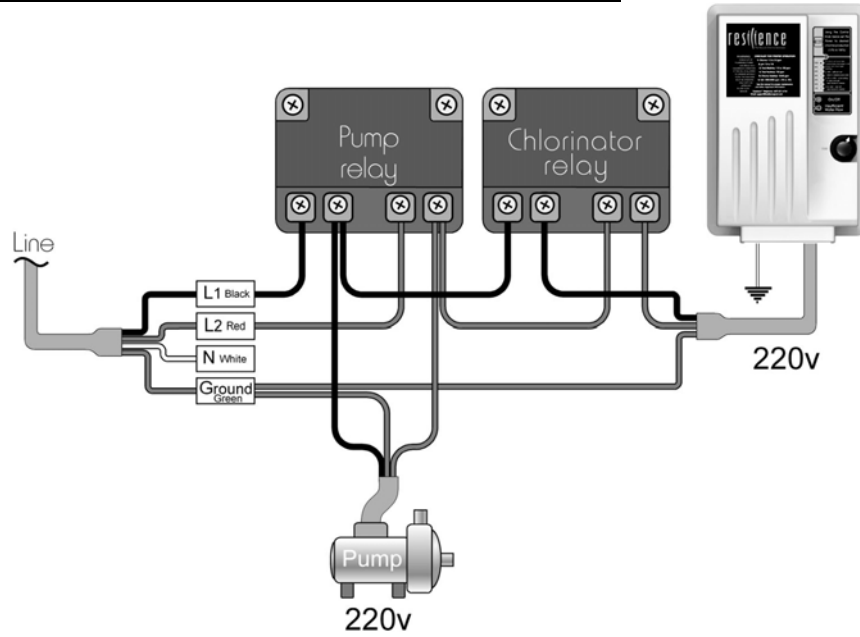

120Volt Circulation Pump With 120 Volt Chlorine Generator

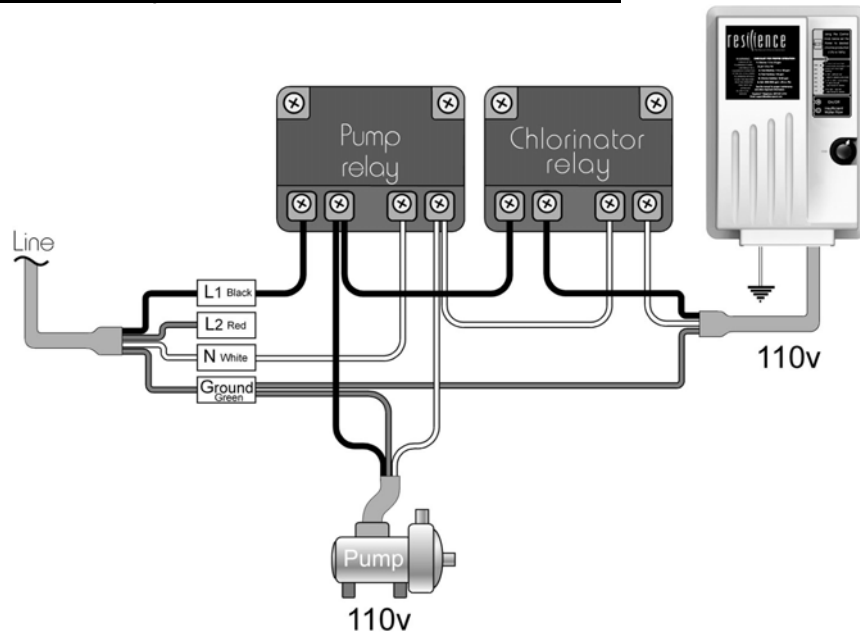

220Volt Circulation Pump With 110 Volt Chlorine Generator

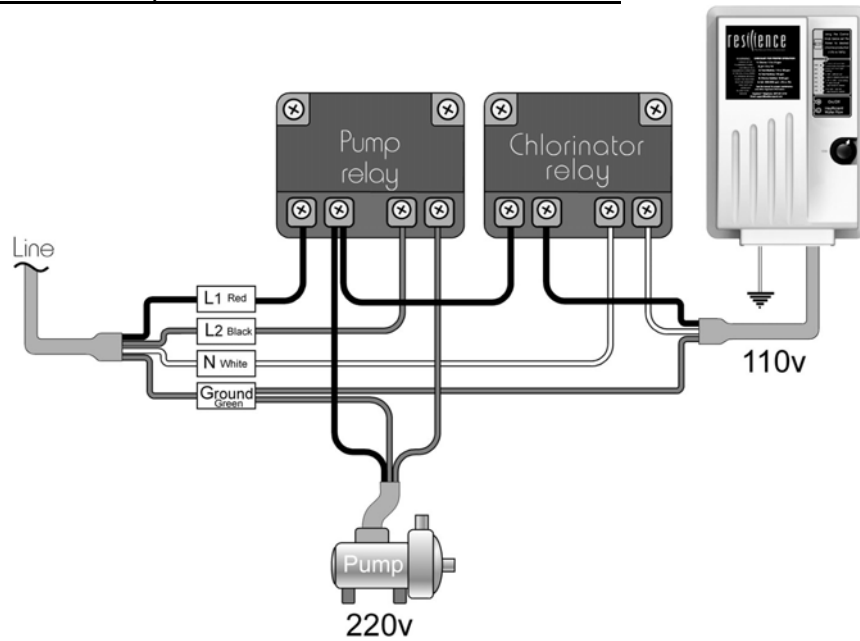

120Volt Circulation Pump With 240 Volt Chlorine Generator

A 240 Volt Chlorine Generator may NOT be connected to a system with a 120 Volt circulation pump.

Wiring the Cell

Connect the two black wires from the Control Box to the two metal studs on the sides of the Cell and **tighten firmly with a screwdriver by hand**. To avoid damage to the screws, DO NOT use a power screwdriver. Note these wires are interchangeable. Push the plastic terminal covers up to cover the terminal connection until they click into place. This will ensure a watertight connection.

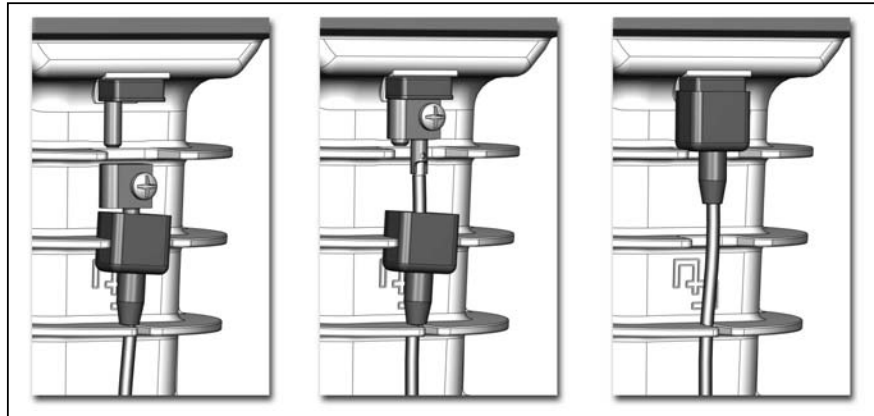

Wiring the Flow Sensor

Find the two 18 AWG wires with the ¼" Quick connect terminals from the Cell cable and push them on their respective connectors on the Flow Sensor. These wires are interchangeable.

STARTUP

BEFORE ADDING THE SALT

- Balance the chemicals. See the titled “Understanding the Chemistry” for recommended water balance. Also, add 1 quart of metal remover and 1 quart of non-copper based algaecide to the pool, according to the manufacturers instructions. This will ensure that the transition to the Natural Chlorine Generator system will be quick and trouble-free.
- Measure existing salt in your pool. Years of liquid chlorine use may cause the salt reading to be higher due to residual salt.
- New Pools: Wait 10-14 days, or longer if specified by the pool builder, for plaster to cure before adding salt or operating the Natural Chlorine Generator.
- Biguanide Pools: If installing on a pool using Biguanide sanitizers, all Biguanides must be removed before system startup.

ADDING THE SALT

1. Determine how much salt is needed from the Salinity Demand Table on the following page. This table is based on a salt concentration of 3500 ppm (approximately 1/3 of 1%). More may be added for larger pools (e.g. 4000 ppm) and less for very small bodies of water.
2. Keep the pump on to circulate the water.
3. Distribute the determined amount of salt evenly around the pool. To avoid clogging the filter or damaging the Control Box and pump, do not add salt through the skimmer or surge tank. Brushing the bottom helps dissolve the salt.
4. The readout on the chlorine generator may fluctuate until the salt is fully dissolved.

ACCEPTABLE SALTS

GOOD	BAD – do NOT to use:
The best salt is an evaporated, granulated, food quality salt.	Iodized salt.
Water softener salt pellets may be used but will take longer to dissolve.	Salts with anti-caking agents of more than 1% (i.e. yellow prussiate of soda or sodium ferrocyanide) because they have iron and will yellow the fittings.
“99.9%” pure salt.	Rock salt because of the dirt mixed with the rock salt.
“Solar” salt.	Calcium chloride; it is not a salt. Use only sodium chloride.

SALINITY DEMAND TABLE (in lbs.)

Salt level before addition in PPM

0	500	1000	1500	2000	2500	3000	3500	4500
---	-----	------	------	------	------	------	------	------

How much salt to add – in pounds

Water volume in thousands of Gallons	4	117	100	83	67	50	33	17	0	OK
	6	175	150	125	100	75	50	25	0	OK
	8	234	200	167	133	100	67	33	0	OK
	10	292	250	209	167	125	83	42	0	OK
	12	350	300	250	200	150	100	50	0	OK
	14	409	350	292	234	175	117	58	0	OK
	16	467	400	334	267	200	133	67	0	OK
	18	525	450	375	300	225	150	75	0	OK
	20	584	500	417	334	250	167	83	0	OK
	22	642	550	459	367	275	183	92	0	OK
	24	701	600	500	400	300	200	100	0	OK
	26	759	651	542	434	325	217	108	0	OK
	28	817	701	584	467	350	234	117	0	OK
	30	876	751	626	500	375	250	125	0	OK
	32	934	801	667	534	400	267	133	0	OK
	34	992	851	709	567	425	284	142	0	OK
	36	1051	901	751	600	450	300	150	0	OK
	38	1109	951	792	634	475	317	158	0	OK
	40	1168	1001	834	667	500	334	167	0	OK
	42	1226	1051	876	701	525	350	175	0	OK
44	1284	1101	917	734	550	367	183	0	OK	
46	1343	1151	959	767	575	384	192	0	OK	
48	1401	1201	1001	801	600	400	200	0	OK	
50	1460	1251	1043	834	626	417	209	0	OK	

→ Locate the current salt concentration at the top of the chart (e.g. 1000ppm). Then locate the size of your pool on the left (e.g. 12,000 gallons). Run these figures down and across until they meet. That number is the number of pounds of salt required for your pool.

CALCULATING THE SIZE OF THE POOL

	Gallons (dimensions are in feet)	Liters (dimensions are in meters)
Rectangular	Length x Width x Average Depth x 7.5	Length x Width x Average Depth x 1000
Round	Diameter x Diameter x Average Depth x 5.9	Diameter x Diameter x Average Depth x 785
Oval	Length x Width x Average Depth x 6.7	Length x Width x Average Depth x 893

OPERATING INSTRUCTIONS

BACKGROUND

This product is an automatic Natural Chlorine Generator for pool and/or spa sanitation. It is the workhorse of chlorine generators. The system uses a very low concentration of salt, less than the concentration in a human teardrop, and converts it into free chlorine that kills algae and bacteria in your pool. After killing the algae and bacteria, the chlorine reverts back into sodium chloride. This process of purification continues, making the need to add extra sanitizing chemicals to your pool virtually unnecessary.

The level of necessary chlorine in the pool is affected by a number of factors such as sunlight, bather load, debris and water temperature, all of which increase sanitation and filtration demand.

Filtration

Proper filtration is critical for maintaining clean healthy water. Filtration increases clarity, and the Natural Chlorine Generator increases sanitation and oxidation. It is customarily required in the pool industry that all the water in the pool pass through the filter at least one and a half (1 ½) times per day (~ 8 hours on most pools). During very heavy usage, the filter and chlorine generator may be run continuously.

→ **Inadequate filtration:** Inadequate filtration reduces water clarity and makes more work for the generator.

Sanitation/Oxidation

The Natural Chlorine Generator has little effect on pH, total alkalinity, or stabilizer levels. These must still be monitored and adjusted to allow the system to have its greatest effect. If you use a good quality pool test kit and follow the simple instructions outlined in this manual, your Natural Chlorine Generator will help you maintain a sparkling clean, trouble-free pool for many years with minimal effort. See the section titled “Understanding the Chemistry” for more information.

BASIC OPERATION

The Natural Chlorine Generator produces a pure form of chlorine to sanitize and oxidize your pool water. The chlorine residual needs to be maintained at 1-3 ppm. This may be tested using a standard kit or by your local pool store. To obtain the optimal residual build up of chlorine, the best time to run your filter is in the early morning and after 4:00 pm when there is less UV to destroy the chlorine produced, leaving chlorine in the pool to oxidize the unwanted foreign matter.

To generate more chlorine:

1. Turn the Control Knob to a higher setting as necessary, 10% to 100% chlorine production level. See “Power Meter” in the next section for more details.
2. Ensure sufficient run time (at least 8 hours / 1 ½ turnovers).
3. Ensure salt level is correct and the Cell is clean (see “Salinity Indicator” in the next section).
4. Ensure proper water balance including pH and stabilizer levels (see “Understanding the Chemistry” for recommended levels).
5. Point pool jets down and to the side.

* Summer weather increases demands for chlorine.

To decrease chlorine production:

1. Turn the Control Knob to a lower setting, 10% to 100% chlorine production level. (See “Power Meter” in the next section)
2. Decrease run time as necessary.

Winterizing

Just like the pool plumbing, freezing may damage the system’s Cell and Flow Sensor. If severe or extended periods of freezing temperatures are possible, drain all water from the pump, filter, and supply and return lines before any freezing conditions occur.

Spring Start-up

DO NOT turn on the system until the pool water chemistry has been brought to required levels. See “Startup” section for more information.

CONTROLS

Control Knob (1) – The *Control Knob* is used to adjust chlorine production and to turn the unit on or off. To increase chlorine production, turn the *Control Knob* up (clockwise). To decrease chlorine production, turn the *Control Knob* down (counterclockwise). To turn the unit off, turn the *Control Knob* down (counterclockwise) until it reaches its end position.

→ **NOTE:** When changing the power setting, the system takes up to 1 minute to ramp up (i.e. soft start). During this time, the green *On/Off Light (4)* will flash.

Power Meter (3) – The Power Meter lights indicate the system's chlorine output (i.e. 10% to 100% production rate). The higher lights indicate higher chlorine production.

A **Solid Red Light (2)** above the *Power Meter (2)* indicates that the salt level in the pool is on the high side. This does not harm the Natural Generator, but is provided as a cautionary notice to the user not to add more salt to the pool. Operation at very high levels (i.e. above about 5500ppm) is not recommended.

A **Flashing Red Light (2)** above the *Power Meter (2)* indicates that the salt level is exceedingly high (i.e. above about 7000ppm), and should be reduced immediately by draining a significant amount of pool water and refilling the pool. (Please check with your local pool professional prior to draining the pool)

Flow Light (5) – This red light should NOT be illuminated during normal operation. When first turning on the circulation pump, the red *Flow Light (5)* may turn on and off until the air is pushed out of the pump lines and sufficient water flow is achieved. This is normal and ensures that the generator automatically shuts off if the pump fails to prime or a blockage occurs. See troubleshooting section if the red *Flow Light (5)* remains on.

On/Off Light (4) – When the system is turned on and the pump is operating, the *On/Off Light (4)* will illuminate indicating that power is reaching the Control Box. The color of the *On/Off Light (4)* indicates the following:

- Solid Green – system is operational.
- Flashing Green – system is performing a “soft start”; light will turn solid green within 1 minute.
- Flashing Green – reversing polarity; light will turn solid green within 3 minutes.

Boost Button (6) – Press this button to automatically turn the system to full power for only 24 hours of actual operation (the Boost Button will flash red and the power meter will indicate 100%). After 24 hours of runtime (or pressing the Boost button again), the system will automatically revert to the power setting of the *Control Knob (1)*. This feature is handy for temporarily increasing the sanitation level in the pool before and/or after a pool party, heavy rains etc.

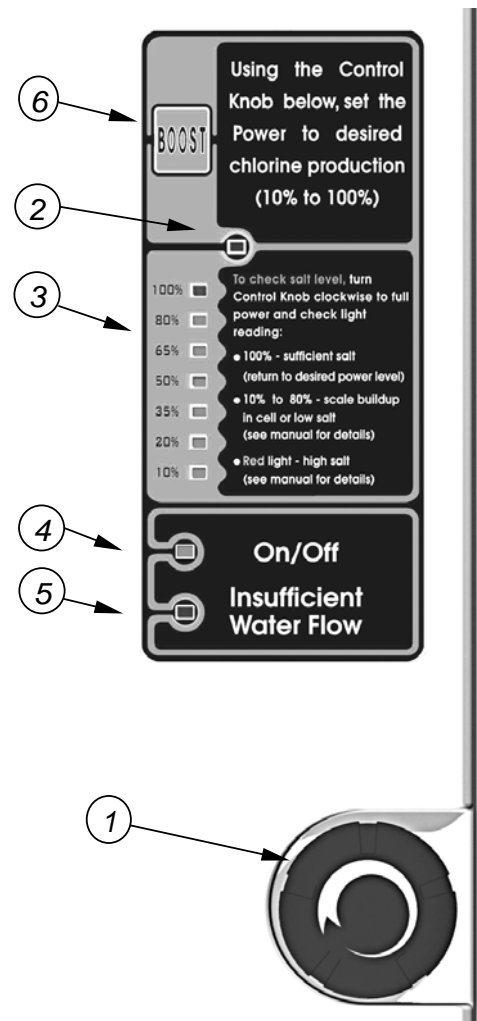

Salinity Indicator – To check the salt level, turn the Control Knob clockwise to full power and wait until power light stops flashing, then check the light reading.

100% reading indicates that the salt level is sufficient. Return the Control Knob to the desired chlorine production setting depending on the chlorine level in your pool (10% to 100% production rate).

Solid Red Light - above the Power Meter indicates that the salt level in the pool is on the high side. This does not harm the Natural Generator, but is provided as a cautionary notice to the user not to add more salt to the pool. Operation at very high levels (i.e. above about 5500ppm) is not recommended. Slowly turn down the Control Knob until the desired Power Meter light illuminates (i.e. desired chlorine production level).

Flashing Red Light above the *Power Meter* indicates that the salt level is exceedingly high (i.e. above about 7000ppm), and should be reduced by draining a significant amount of pool water and refilling the pool. (Please check with your local pool professional prior to draining the pool)

If Power Meter lights go up & down quickly: The salt level is extremely high, and should be reduced immediately by draining a significant amount of pool water and refilling the pool. (Please check with your local pool professional prior to draining the pool).

Readings between 10% and 80% indicate a low salt level, except when the Cell is worn or calcified. Check the Cell to ensure the blades are in good condition and not coated with calcium buildup. Cleaning the Cell is recommended if it is calcified or if the readout seems questionable. Before adding salt, it is advisable to have the salt level professionally checked.

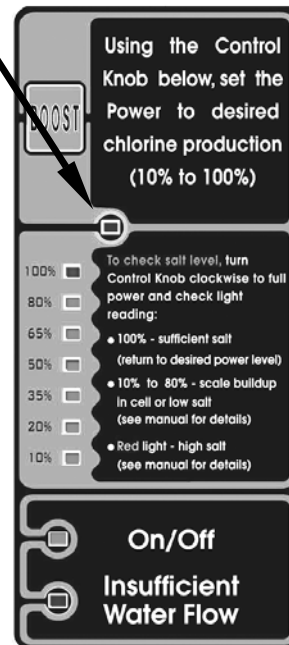

MAINTENANCE

Maintaining your Natural Generator requires minimal work but will maximize the performance and life of the system.

→ **POOL WATER TESTING:** Pool water should be tested at least once per month.

Cell Maintenance

Our clear Cell allows for easy regular inspections for calcium build up. Visually check the Cell periodically, and clean it as necessary (1 to 2 times per year). Advanced self-cleaning technologies, including reverse polarization and IBT™ help the cell stay cleaner than other self-cleaning cells, but bi-annual cleanings are required.

Cell Cleaning

→ **Do Not use metal or other hard objects to clean the cell** as this could scratch the precious coating on the plates and void the warranty.

→ **CAUTION: Always add acid to water, NOT water to acid**

Diluted muriatic acid solution = 10 parts water to 1 part acid

Note: Follow the instructions of the acid manufacturer.

Cleaning With Optional Cleaning Cap:

1. Remove the cell from the line by undoing the barrel unions from the cell ends. There is no need to remove the wire connections when using the cleaning cap.
2. Remove the black o-rings on the ends of the Cell.
3. Attach the Cell Cleaning Cap to one end of cell.
4. Pour into Cell, either undiluted white distilled vinegar, or a solution of diluted muriatic acid (10 parts water to 1 part muriatic acid).
5. Wait for foaming to stop (5-10 minutes when using muriatic acid, vinegar takes longer).
6. If muriatic acid was used, safely dispose of it by pouring it into your pool.
7. Rinse cell with water hose.
8. Put the O-ring back in place and re-install the Cell in the line.
9. Reconnect the electrical wires, being sure to tighten the screws on the electrical wires firmly.

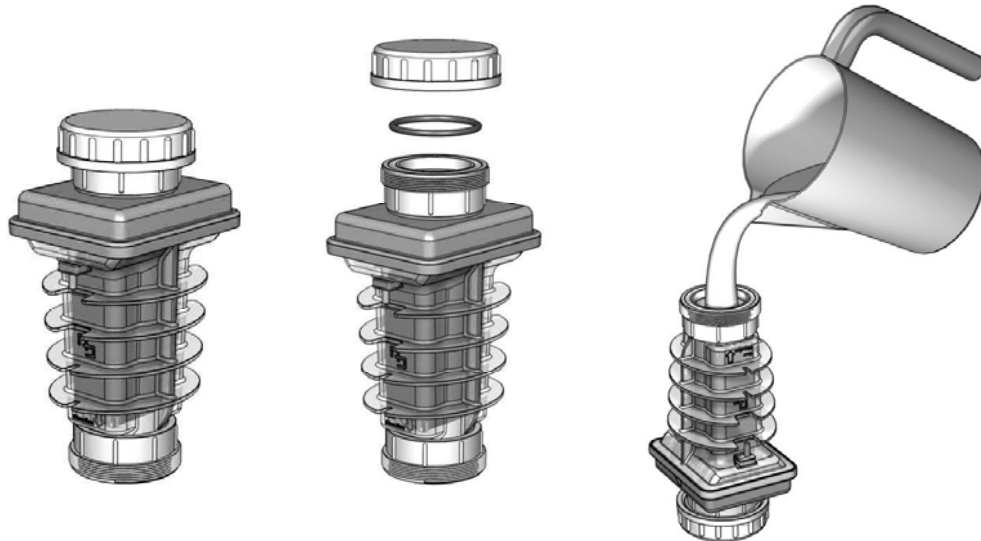

Cleaning Without Optional Cleaning Cap:

1. Remove the cell from the line by undoing the electrical connections from the Cell and the barrel unions from the cell ends.
2. Remove the black o-rings on the ends of the Cell.
3. Soak entire cell either in undiluted white distilled vinegar or in a solution of diluted muriatic acid (10 parts water to 1 part muriatic acid).
4. Wait for foaming to stop (5-10 minutes when using muriatic acid; vinegar takes longer)
5. If muriatic acid was used, safely dispose of it by pouring it into your pool.
6. Rinse cell with water hose.
7. Put the O-ring back in place and re-install the Cell in the line.
8. Reconnect the electrical wires, being sure to tighten the screws on the electrical wires firmly.

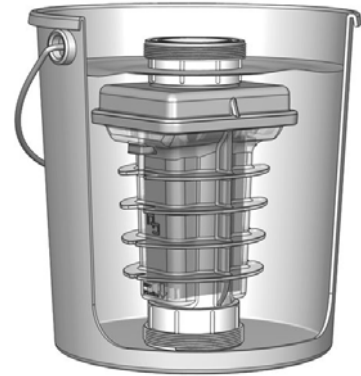

Optional

1. Lubricating the o-rings with a rubber lubricant (e.g. silicone) helps improve the seal of the fittings, but be sure not to use silicone glue, petroleum jelly (such as Vaseline), or other agents that could deteriorate the o-rings.
2. Smear the two electrical connections on the outside of the cell with electrical lubricant.

UNDERSTANDING THE CHEMISTRY

Below is a table showing the recommended balance levels followed by a more detailed explanation of the factors affecting water chemistry. Maintaining these levels will prevent corrosion and scaling and will ensure maximum enjoyment of the pool. You should test your water periodically. If the water chemistry needs adjustment, your authorized dealer or most pool stores can supply you with the appropriate chemicals and procedures. We recommend you either take a copy of the Water Balance Table to the pool store or notify the pool store that you are using a salt chlorine generator.

FACTORS	IDEAL LEVELS
Salt	3000 to 4000 ppm
Free Chlorine	1 to 3 ppm
PH	7.2 to 7.6
Total Alkalinity	110 to 180 ppm (Depending on the Saturation Index)
Stabilizer (Cyanuric Acid)	60-80 ppm
Nitrates	0 ppm
Metals	0 ppm
Phosphates	0 ppm, or as low as possible
Calcium Hardness	Determine level for individual pool finish
Saturation Index	-0.3 to 0.3 (0 is ideal)

Salt

Salt is the power source of the Natural Chlorine Generator. To ensure maximum benefits with the use of the system, the ideal salt level is 4000 ppm (parts per million). A low concentration of salt can hinder the generator's effectiveness. A concentration of salt above 5500 ppm may cause corrosion damage to the pool fixtures. See the Adding Salt section for more information.

Total Dissolved Solids (TDS) are different from the salt level of the pool, although TDS levels rise by adding salt to pool water. This does not harm the pool water chemistry or clarity, but the pool water professional that is testing for TDS must be aware that salt has been added for the chlorine generator system. The pool professional doing the TDS test will get the accurate TDS level by subtracting the salinity level.

Free Chlorine v. Combined Chlorine: The unpleasant smells and side effects often associated with chlorine are actually caused by combined chlorine (i.e. chloramines). Combined chlorine is a chlorine molecule that attacked a noxious particle in the water but has been unable to destroy that noxious particle. This chlorine particle remains attached to the noxious particle until one of the two is burned off; hence the term "combined chlorine" (a.k.a. chloramines). To burn off the noxious particle and free up the chlorine again, pool owners have had to shock the pool periodically, but with the Natural Chlorine Generator, the noxious particles are burned off within the generator's Cell and the combined chlorine is continuously converted back to free chlorine.

The free chlorine level in the pool should be maintained at 1 to 3 ppm. This level of free chlorine is comfortable to swim in with no unpleasant smells, and it maintains proper sanitizing power.

PH is a measure of how acidic or basic a solution is. A scale of 0 to 14 is used to measure pH. Pure water has a pH of 7 (neutral), acid solutions have a pH of less than 7, and basic (alkali) solutions have a pH of more than 7. The recommended range is 7.2 to 7.6; chlorine is more effective within this range and the water is most comfortable for bathers. Water with very high pH levels can cause scaling in the pool, on the walls and in pipes. Low pH levels cause the water to be aggressive to the pool walls, equipment, and bathers.

To lower pH, add muriatic acid or dry acid, and to raise pH, add soda ash (sodium carbonate). Be sure to read and follow the respective manufacturer's instructions.

Total Alkalinity mitigates changes in pH. It is often referred to as the “big brother of pH.” Keeping proper levels of total alkalinity will help reduce unwanted fluctuations in pH levels. Total alkalinity is also used to offset high or low levels of calcium hardness (see Saturation Index below). Add muriatic acid or dry acid to lower total alkalinity and add baking soda (sodium bicarbonate) to raise total alkalinity. Be sure to read and follow the respective manufacturer’s instructions.

Stabilizer (cyanuric acid) is necessary in most outdoor pools to maintain appropriate levels of chlorine. Chlorine stabilizer helps give an appropriate residual chlorine reading of the pool water. Without stabilizer, UV radiation from the sun destroys most chlorine within 2 hours, but excessive amounts of stabilizer can decrease the effectiveness of chlorine. Chlorine stabilizer should be maintained at 40 ppm to offset the harmful effect of the sun while maintaining the effectiveness of the chlorine.

Nitrates and Phosphates, generally associated with fertilizer thrown on nearby grass, can put very high demands on chlorine; most often nitrates and phosphates will bring the chlorine level down to zero (0). You can have your water tested for nitrates and phosphates by the local pool professional. **No nitrates or phosphates should be in your pool.** To reduce phosphate levels, use a phosphate remover from your local pool professional. To reduce Nitrate levels, the pool must be partially or fully drained. (Please check with your local pool professional prior to draining the pool)

Metals (certain metals) can cause loss of chlorine and can stain your pool. If a water test reveals the presence of metals, refer to your local pool professional for recommended methods of removal.

New Pool Water in recently filled or newly refinished pools may contain undesirable matter. The ability of the Natural Chlorine Generator to purify your pool could be hindered by this matter so it is best to balance the pool chemicals first.

Calcium Hardness, like pH and alkalinity, affects the water’s tendency to be aggressive or scale forming. Lower levels of calcium hardness improve the chlorine generator’s performance and provide softer silkier water for the swimmers.

Saturation Index determines whether the pool water is balanced, aggressive, or scale forming by comprehensively taking into account all the relevant factors, including pH level, alkalinity level, calcium hardness, and temperature. These factors should be tested periodically then plugged into the worksheet on the following page to verify the proper balance of the pool and make adjustments as necessary.

SATURATION INDEX

Test the water for pH, Alkalinity, Calcium Hardness, and Temperature, then follow the simple steps below:

1. Write your pool's pH level here: _____ → pH: _____

2. Find your Alkalinity level in the chart below, and write the corresponding Alkalinity Factor here: _____ → Alkalinity Factor: _____

Pool Alkalinity	5	25	50	75	100	150	200	300	400
Factor	0.7	1.4	1.7	1.9	2.0	2.2	2.3	2.5	2.6

3. Find your Calcium level in the chart below, and write the corresponding Calcium Factor here: _____ → Calcium Factor: _____

Pool Calcium (CaCO ₃)	5	25	50	75	100	150	200	300	400
Factor	0.3	1.0	1.3	1.5	1.6	1.8	1.9	2.1	2.2

4. Find your pool temperature in the chart below, and write the corresponding Temperature Factor here: _____ → Temperature Factor: _____

Pool Temp	32	37	46	53	60	66	76	84	94	105
Factor	0.0	0.1	0.2	0.3	0.4	0.5	0.6	0.7	0.8	0.9

5. Add the results from steps 1 through 4 above and write the result here: _____ Total of above: _____

 - 12.2

6. Subtract 12.2 from step 5 and write the result here: _____ → Saturation Index =

- If the Saturation Index above is between -0.3 and +0.3, the water is well balanced.
- If the Index is more than 0.3, the water will tend to cause scaling or get cloudy. Alkalinity and pH should be reduced accordingly, but maintained within recommended levels.
- If the Index is less than -0.3, the water will tend to be aggressive toward the pool surface, equipment, and bathers. Alkalinity and pH should be increased accordingly, but maintained within recommended levels.

TROUBLESHOOTING

Note: evaluating the possible causes for each problem from top to bottom (first to last) will avoid extra labor.

PROBLEM	POSSIBLE CAUSES	WHAT TO DO
1. Chlorine Level Low	➤ System is turned off.	➤ Turn Control Knob to the desired setting.
	➤ Control Knob is set too low in relation to chlorination demand (e.g. higher number of bathers, warmer weather, increased debris in pool).	➤ Turn Control Knob higher (clockwise) and/or increase pump operation time.
	➤ Low Salinity	➤ Check the salinity level. (See "Salinity Indicator" section).
	➤ Pump operation time too short	➤ Run pump at least 8 hours per day (1.5 turnovers of all the pool water).
	➤ Low Stabilizer (Cyanuric Acid)	➤ Check water chemistry; stabilizer should be between 40-80 ppm. If low, add stabilizer (See "Understanding the Chemistry").
	➤ Chemical Imbalance	➤ Check other chemistry and balance chemicals. (See "Understanding the Chemistry").
2. Green Pool	➤ Chlorine level too low.	➤ See "Chlorine Level Low" above.
3. On/Off Light is OFF: No power	➤ System is turned off.	➤ Turn Control Knob clockwise to the desired setting.
	➤ Main fuse blew.	➤ Check main fuse on bottom of Control Box and replace if necessary with a 6.3 Amp 250VAC 6x32mm Slow Blow fuse. One extra fuse is supplied on the bottom-side of the Control Box cover.
	➤ Breaker jumped	➤ Check the breaker leading to the pool control.
	➤ Power wires cut, disconnected, or incorrectly wired.	➤ Check for correct wiring.
	➤ Other malfunction in Control Box.	➤ Contact warranty hotline.
4. On/Off Light is Solid Green	➤ System is on. This is normal.	
5. Red Flow Light is Off	➤ This is normal.	
6. Flow Light is Turning On and Off	➤ This is normal at initial start-up or if air bubbles are in pipes.	➤ Wait a few minutes for air to clear. If continuous, see troubleshooting section "Flow Light is Solid Red" below.
7. Flow Light is Solid Red	➤ Insufficient water flow from pump to Flow Sensor and Cell.	➤ This is normal for a few minutes at initial startup or if air is in the lines. ➤ Clean filters and strainers. ➤ Check for closed valves, faulty pump, etc.
	➤ Obstruction or scale buildup in Cell.	➤ Clean Cell according to instruction manual. (See "Maintenance" section)
	➤ Flow Sensor was not installed in the correct direction.	➤ Turn Flow Sensor so arrow faces direction of water flow.
	➤ Flow Sensor is not fully threaded into the "T" connector.	➤ Fully thread the Flow Sensor into the T connector being careful not to damage the wires or sensors.
	➤ Cut wires or insufficient wire connections.	➤ Check the connection to ensure proper wire contact.
8. Power Meter lights do not reach 100%	➤ Control Knob set too low	➤ Turn Control Knob higher (clockwise). ➤ If the red light above the Power Meter illuminates or if the lights go up and down, see Troubleshooting Section "Salinity High" below.
	➤ Dirty Cell, Loose Connection, or Salinity Low.	➤ See Troubleshooting Section "Salinity Low" below.

TROUBLESHOOTING

Note: evaluating the possible causes for each problem from top to bottom (first to last) will avoid extra labor.

PROBLEM	POSSIBLE CAUSES	WHAT TO DO
9. Salinity Low	➤ Dirty Cell	➤ Check the Cell to ensure the blades are in good condition and not coated with calcium buildup. Cleaning the Cell is recommended if it is calcified or if the readout seems questionable. (See “Cell Cleaning” under the “Maintenance” section).
	➤ Loose connection with the Cell’s connection pegs.	➤ Ensure the connectors are pushed completely over the pegs and tighten connections with a screwdriver.
	➤ Low pool water temperature.	➤ In very cold water temperature the salt meter may indicate a lower salinity level, this is normal.
	➤ Not enough salt due to heavy rain, initial miscalculation, etc	➤ Add salt into the pool. See the “Adding The Salt” section for more information.. ➤ It is also recommended to periodically test the salt level by a professional and adjust according to the “Salinity Demand Table” in this manual.
	➤ Worn Cell	➤ If none of the above resolutions worked, the cell may be worn out.
10. Salinity High	➤ Salinity High. Enough salt has been added causing the red light above the power meter to light.	➤ This does no harm to the Natural Generator, but simply indicates that the salt level is on the high side for your information. ➤ It is also recommended to periodically test the salt level by a professional. If above 5500 ppm, it is recommended to drain part of the pool water and refill with fresh water. (Please check with your local pool professional prior to draining the pool)
	➤ Salinity is very high. Too much salt has been added causing the red light above the power meter to flash.	➤ The salt level is very high. Drain part of the water and refill the pool to bring the salinity down. ➤ It is also recommended to periodically test the salt level by a professional. If above 5500 ppm, it is recommended to drain part of the pool water and refill with fresh water. (Please check with your local pool professional prior to draining the pool)
	➤ Salinity far too high. Way too much salt has been added causing the Power Meter to run up and down quickly.	➤ The salt level is exceedingly high. Drain part of the water and refill the pool to bring the salinity down. ➤ It is also recommended to periodically test the salt level by a professional. If above 5500 ppm, it is recommended to drain part of the pool water and refill with fresh water. (Please check with your local pool professional prior to draining the pool)
11. RED light at the top of the Power Meter is lit	➤ Salinity high	➤ See Troubleshooting Section “Salinity High” above.
12. Lights go up & down quickly	➤ Salinity is very high.	➤ Drain part of the water and refill the pool to bring the salinity down. See Troubleshooting Section “Salinity High” above for more information. ➤ It is also recommended to periodically test the salt level by a professional. If above 5500 ppm, it is recommended to drain part of the pool water and refill with fresh water. (Please check with your local pool professional prior to draining the pool)
	➤ “Short Circuit” in the cell wires.	➤ Check that the cell wires are properly fastened and there is no reason for short circuit between them.

TROUBLESHOOTING

Note: evaluating the possible causes for each problem from top to bottom (first to last) will avoid extra labor.

PROBLEM	POSSIBLE CAUSES	WHAT TO DO
13. Power Meter not responding, but On/Off light is on	➤ Control Knob set too low	➤ Turn Control Knob up (clockwise).
	➤ Improper salt level. The system automatically shuts down the Power Meter when the salt level is extremely low or extremely high.	➤ Check salt level using a test kit or your local pool professional. The salt level is likely at an extreme level. Adjust accordingly.
	➤ Boost Button pressed "ON"	➤ Check if Boost function was activated. Press the Boost Button one more time to exit Boost mode and activate the Power Meter Knob.
14. Scale build-up inside Cell	➤ Standard occurrence that needs to be cleaned approximately twice/year.	➤ Clean Cell as instructed in the "Maintenance" section.
	➤ Chemical imbalance.	➤ Balance chemicals. (Focus mostly on the "Saturation Index" in the section titled "Understanding the Chemistry").
15. White flakes in the water	➤ Normal occurrence when Cell cleans itself.	➤ Keeping the water well balanced reduces this occurrence. (Focus mostly on the "Saturation Index" in the section titled "Understanding the Chemistry").
16. Cloudy water	➤ May be due to chemical imbalance or low water flow	<ul style="list-style-type: none"> ➤ Make sure your filtration system is working properly (i.e. clean filter and/or skimmer). ➤ Make sure circulation time is adequate – increase pump time if not. ➤ Make sure total alkalinity is balanced. ➤ Shock the water to eliminate build up of any organic matter. ➤ Make sure pool has free chlorine reading of 1.0 to 3.0 ppm ➤ Check with dealer for more information
17. Colored Water	<ul style="list-style-type: none"> ➤ Metals in the fill water may have been oxidized. ➤ Algae may be trying to form. 	<ul style="list-style-type: none"> ➤ Have dealer test the pool water. If high in metals use a Metal out or Sequestering product at start-up only. ➤ Increase circulation time if needed and clean the filter. ➤ Check with your dealer for more information.
18. Algae	➤ May be due to low chlorine levels or a chemical imbalance	<ul style="list-style-type: none"> ➤ Have your water tested for chemical balance including pH, phosphates, and nitrates. ➤ Use a nonmetallic (polyquat) algacide per the directions on the bottle and brush the sides of the pool often. ➤ Clean the filter and shock the pool with chlorine daily until water clarity returns. ➤ Check with your dealer for more information.

Our contact information is found on the front cover of this manual. For additional information, please visit our website. For warranty service, questions, or comments, please contact us directly. Technicians are available from 9:00 AM to 5:00 PM Eastern Standard Time, Monday through Friday. Please have the following information ready:

1. Model and Serial # of Control Box and Cell
2. Date of installation
3. Installing company or dealer
4. Current salt level and chemical levels
5. Proof of Purchase (bill of sale, cancelled check, or some other appropriate payment record)

Seven (7) Year Limited Warranty

Model: PSC-2/PSC-3/PSC-4/PSC-5 Types: SCC-12, SCC-25, or SCC-40

WARRANTY

This warranty applies to PSC-2/PSC-3/PSC-4/PSC-5 chlorine generators types SCC-12, SCC-25, or SCC-40 and their factory-supplied components (the "System") when purchased from an authorized dealer and used for residential swimming pools or spas. American Swimming Pool Systems, LLC ("American SPS") and Plastic Magen ("PM") warrant the System to be free from defects in materials and workmanship in the manufacturing process for a period of seven (7) years from the purchase date, when properly installed and operated in accordance with the relevant manuals. For three (3) years after the System's original purchase date, should the System exhibit a manufacturing defect, American SPS will install comparable replacement parts **without charge for parts or labor**. For the subsequent 4 years, if a part with a manufacturing defect is delivered freight prepaid to American SPS, a comparable replacement part will be sent back for a charge of 60% of the latest list price plus the cost of shipping.

EXCEPTIONS & LIABILITY LIMITATIONS

This warranty is not transferable. Labor coverage is applicable only for installations within a 50-mile radius of an authorized dealer. American SPS, PM, and their suppliers, dealers, and distributors SHALL NOT BE LIABLE FOR INCIDENTAL OR CONSEQUENTIAL DAMAGES; DAMAGE OF ANY SORT OR NATURE RESULTING FROM ABUSE, MISUSE, NEGLIGENCE, LIGHTNING, ABNORMAL WEATHER CONDITIONS, OR ACT OF GOD; OR DAMAGE CAUSED BY IMPROPER OR UNAUTHORIZED INSTALLATION OR REPAIR. This warranty applies only to components supplied by the factory and only where such components have been installed and maintained in compliance with the respective installation and operation manuals and instructions and applicable ordinances and codes. In no event shall the liability exceed the purchase price of the product. THE CONSUMER SHALL BE LIABLE AT STANDARD RATES FOR ANY SERVICE VISIT WHERE NO MANUFACTURING DEFECT WAS PRESENT AND FOR ALL SERVICE VISITS REQUESTED AFTER THE THIRD YEAR FOLLOWING THE ORIGINAL PURCHASE DATE.

PROOF OF PURCHASE

The consumer is responsible for establishing the original purchase date and the purchaser's identity for warranty purposes. We recommend that a bill of sale, canceled check, or some other appropriate payment record be kept for that purpose.

The express warranty above constitutes the sole and complete warranty and takes precedence over all other warranties, whether expressed or implied, including a warranty for fitness for a particular purpose. No sales representative, dealer, distributor, or other person is authorized to give any warranty on behalf of PM or American SPS.

Cell Serial # _____
*In the clear section of the cell by cable post.

Control Box Serial # _____
*On the left side of the control box mounted to the wall.



RESILIENCE OWNER'S REGISTRATION FORM 7-YEAR LIMITED WARRANTY

★ Mandatory areas to be filled in for warranty coverage.

★ Owner's Name _____ ★ Signature _____

★ Street Address _____ ★ City _____

★ State _____ ★ Zip _____ ★ Phone # _____ Email Address _____

★ Date of Purchase ____/____/____ Authorized Dealer _____ Sales Rep _____

★ Cell
Serial #: _____
In the clear section of
the cell by cable post.

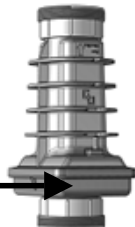

★ Control Box
Serial #: _____
On the left side of the
control box mounted to the wall



How did you hear about our product? (Please check all that apply)

___ Pool Store Employees ___ Pool Builder ___ Pool Service ___ Direct Mail ___ In-Store Display
___ Friend/Relative ___ Magazine ___ Newspaper ___ Radio ___ TV ___ Catalog ___ Other: _____

Comments: _____

If more space is necessary, please utilize the back of this form.

**IN ORDER TO ACTIVATE YOUR WARRANTY
PLEASE RETURN THIS PORTION TO:**

AMERICAN SWIMMING POOL SYSTEMS, LLC
927 Fern Street, Suite 1500 • Altamonte Springs, Florida 32701
Or by Fax: 407.831.1208